

SAFE-GUARD® RETURN IDLER CAGE

Conveyor Safety Product

MEGASUPPLY S.C.R.L.

ASGCO® has long recognized the importance of ensuring safety in the workplace. The **Safe-Guard® Return Idler Cage** was designed to catch the return roller applications from falling, preventing injuries to workers and to equipment. The Safe-Guard® Idler Cage is a cost effective, long lasting solution to your guarding needs.

Catches the return idler if it falls!

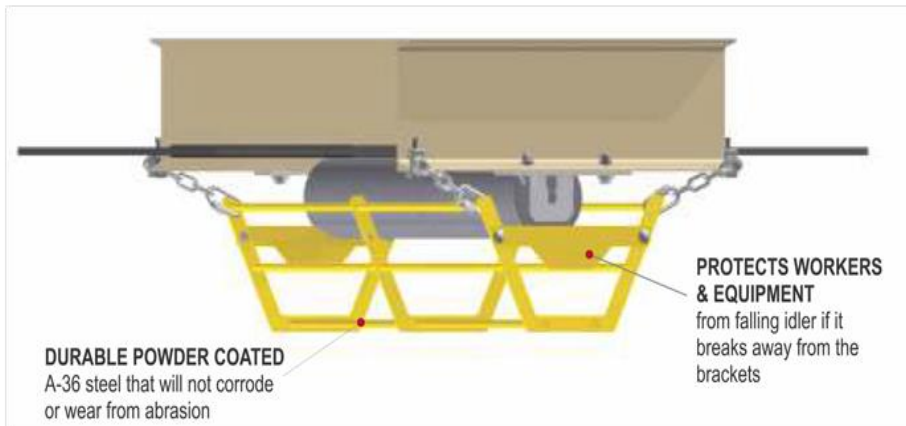

- **Prevents Idlers from Falling** - and injuring workers or equipment.
- **Easy to Install and Remove** - for fast installation and belt maintenance using beam clamp, links and adjustable chain.

- **Complies with MSHA Title 30**

- 56.14110 (Flying or falling material)
- 56.14112 (Guard Construction)
- 56.14107 (Moving machine parts)
- 75.1722 (Mechanical equipment guards)
- 77.400 (Mechanical equipment guards)

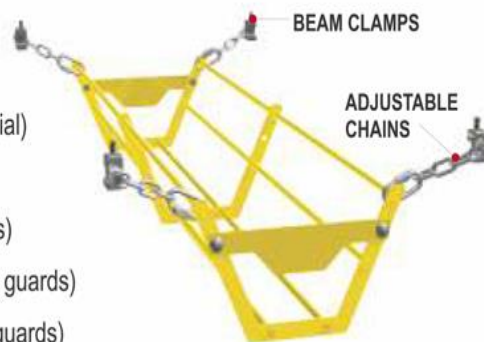

- **Meets OSHA Requirements 1910.219** - for mechanical power - transmission apparatus and 56.14107 for moving machine parts.
- **Durable Powder Coated A-36 Steel Cage** - helps prevent injuries from falling idlers onto unsuspecting workers or equipment. Open slots prevent material build-up.
- **Available in Various Sizes** - to fit most belt conveyors, 4" - 7" diameter rolls.
- **No Welding Required.**

SAFE-GUARD® RETURN IDLER CAGE

Safe-Guard® Return Idler Cage				
Part Number	Belt Width		Cage Length	
	in	mm	in	mm
M-ASG-RIC-18	18	450	28-7/8	733
M-ASG-RIC-24	24	600	34-7/8	886
M-ASG-RIC-30	30	750	40-7/8	1038
M-ASG-RIC-36	36	900	46-7/8	1191
M-ASG-RIC-42	42	1050	52-7/8	1343
M-ASG-RIC-48	48	1200	58-7/8	1495
M-ASG-RIC-54	54	1350	64-7/8	1648
M-ASG-RIC-60	60	1500	70-7/8	1800
M-ASG-RIC-66	66	1650	76-7/8	1953
M-ASG-RIC-72	72	1800	82-7/8	2105
M-ASG-RIC-78	78	2000	88-7/8	2257
M-ASG-RIC-84	84	2100	94-7/8	2410
M-ASG-RIC-90	90	2300	100-7/8	2562
M-ASG-RIC-96	96	2400	106-7/8	2715

*Safe-Guard® Return Idler Cages are NOT used for pinch point protection.
 **Available in all standard conveyor belt widths.

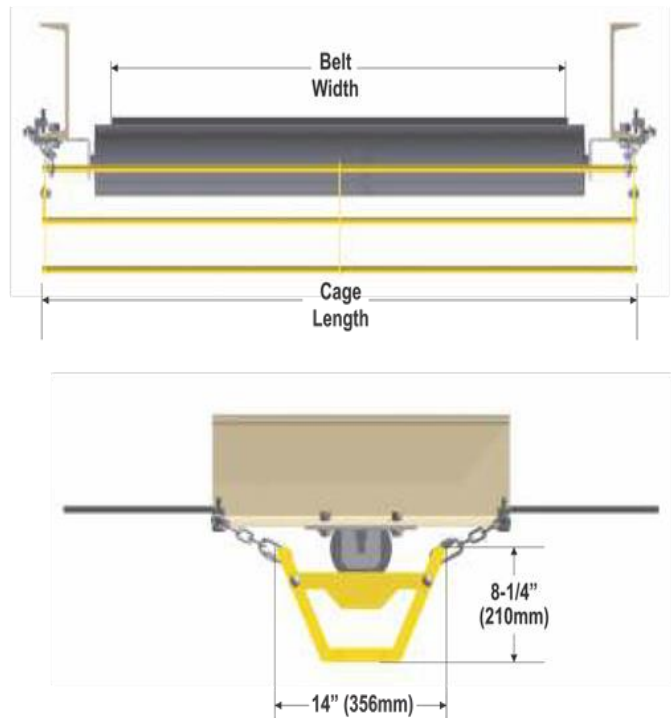

Safe-Guard® Return Tracking Idler Cage				
Part Number	Belt Width		Cage Length	
	in	mm	in	mm
M-ASG-RTC-18	18	450	28-7/8	733
M-ASG-RTC-24	24	600	34-7/8	886
M-ASG-RTC-30	30	750	40-7/8	1038
M-ASG-RTC-36	36	900	46-7/8	1191
M-ASG-RTC-42	42	1050	52-7/8	1343
M-ASG-RTC-48	48	1200	58-7/8	1495
M-ASG-RTC-54	54	1350	64-7/8	1648
M-ASG-RTC-60	60	1500	70-7/8	1800
M-ASG-RTC-66	66	1650	76-7/8	1953
M-ASG-RTC-72	72	1800	82-7/8	2105
M-ASG-RTC-78	78	2000	88-7/8	2257
M-ASG-RTC-84	84	2100	94-7/8	2410
M-ASG-RTC-90	90	2300	100-7/8	2562
M-ASG-RTC-96	96	2400	106-7/8	2715

Safe-Guard® Return Tracking Idler Cage

Designed to protect conventional tracking idlers throughout the market.

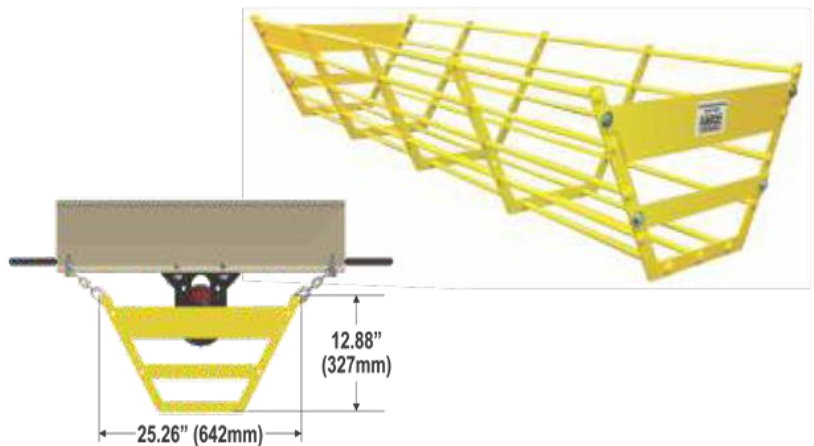

IMPORTANT: The Safe-Guard® Return Idler Cage is designed to catch the return roller applications from falling while the conveyor is running. Installation of this guard does not supersede any other safety procedures or safety practices. Failure to observe all instructions could result in serious injury. It is the owner's responsibility that the owner and each operator read and be familiar with the ASGCO® installation guide.

CAUTION: It is the owner's responsibility to adjust the Safe-Guard® restricting contact with the turning idler.